

SIMPLEX[®]

AUTOMATIC FUELPORT MANUAL

July 2011

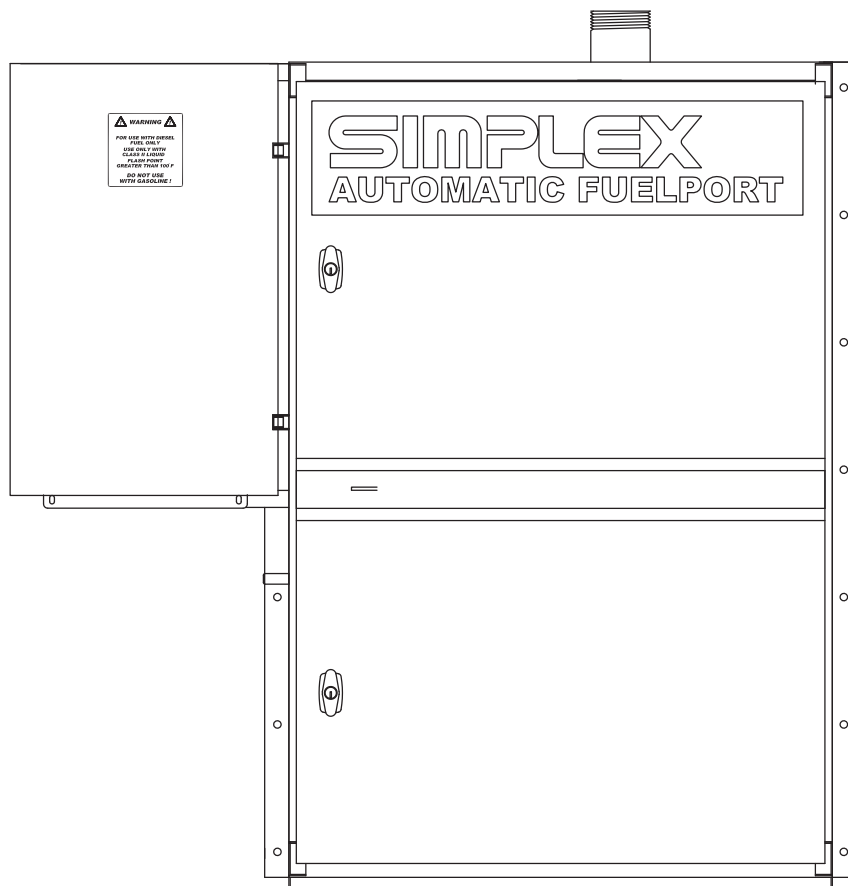

Contents

DESCRIPTION	2
INSTALLATION.....	3
AUTOMATIC FUELPORT	5
SEQUENCE OF OPERATION	5
TC-25 TANK COMMANDER.....	6
INSTALLATION.....	7
LEVEL TRANSMITTER OPERATIONAL VERIFICATION.....	7
FIELD CALIBRATION (MAY BE REQUIRED)	8
INCHES OF FUEL TO OUTPUT CURRENT CONVERSION CHART	10
APPENDIX A - ABBREVIATIONS USED IN THIS MANUAL.....	12
APPENDIX B - TECHNICAL DATA	13

The information herein is the property of Simplex, Inc. and/or its subsidiaries. Without written permission, any copying, transmitting to others, and other use except that for which it is loaned, is prohibited.

DESCRIPTION

The Simplex Automatic FuelPort is a factory packaged system for control of filling operations of above-ground tanks that are filled from pumper trucks. The Automatic FuelPort provides a ready means of ground level connection of the fill hose, and captures spills that may occur at the fill point during filling operations. The Automatic FuelPort alerts the operator when the tank is full with filling operations locked out at High Level. A leak detection circuit prevents filling of leaking tanks. Visual and audible level and leak alarms and continuous level indication are provided.

The Simplex Automatic FuelPort includes an electronic monitor and control system used to control tank filling and prevent overflow. The Automatic FuelPort can be used with an electric solenoid valve or a motorized ball valve.

During filling operations, the Automatic FuelPort provides continuous level indication, Tank Full audible and visual alarm, High Level audible and visual alarm and shut off.

The Automatic FuelPort can receive a signal from an external tank leak sensor to activate an alarm, send a remote signal and automatically close the fill valve.

The Simplex Automatic FuelPort is available for use with fuel oil (Class-II liquids) or gasoline (Class-I liquids).

Single or multiple tank controllers are available. Multiple tank controllers allow operator selection of the tank to be filled with automatic lockout of all other tanks.

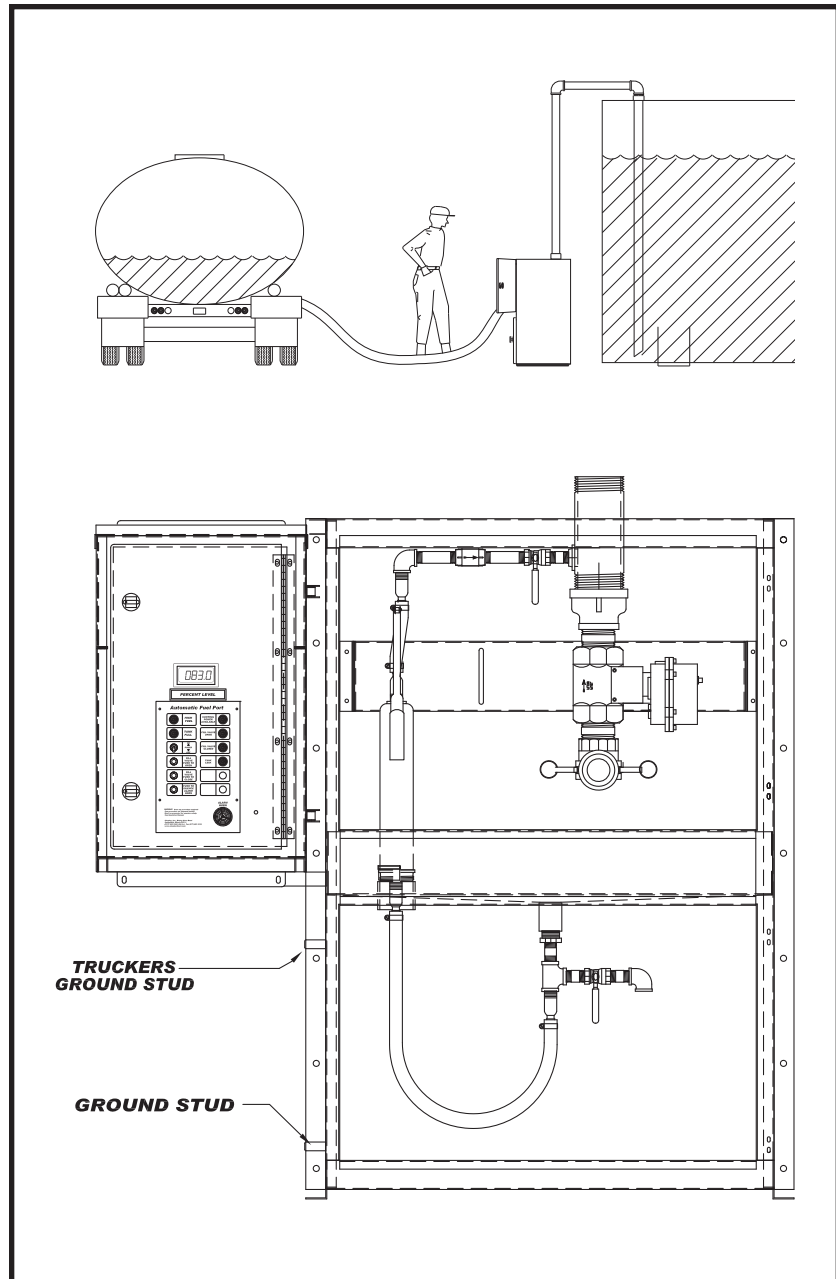

See the Specifications Sheet in the front of this manual for detailed information and a list of drawings for this Automatic FuelPort.

INSTALLATION

1. See Pictorial Drawings:

- a. Properly mount and attach all components as shown using the mounting feet/holes provided.
- b. Install Automatic FuelPort Transducer, Float-switch Assembly and optional Tank Leak Floatswitch, if provided, in the appropriate NPT fittings in the top of the fuel storage tank.
- c. Connect Automatic FuelPort Ground Stud to earthground.

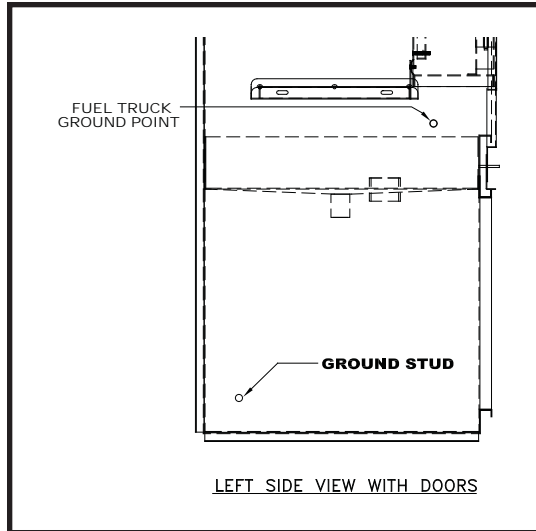

Ground Stud and Fuel Truck Ground Point

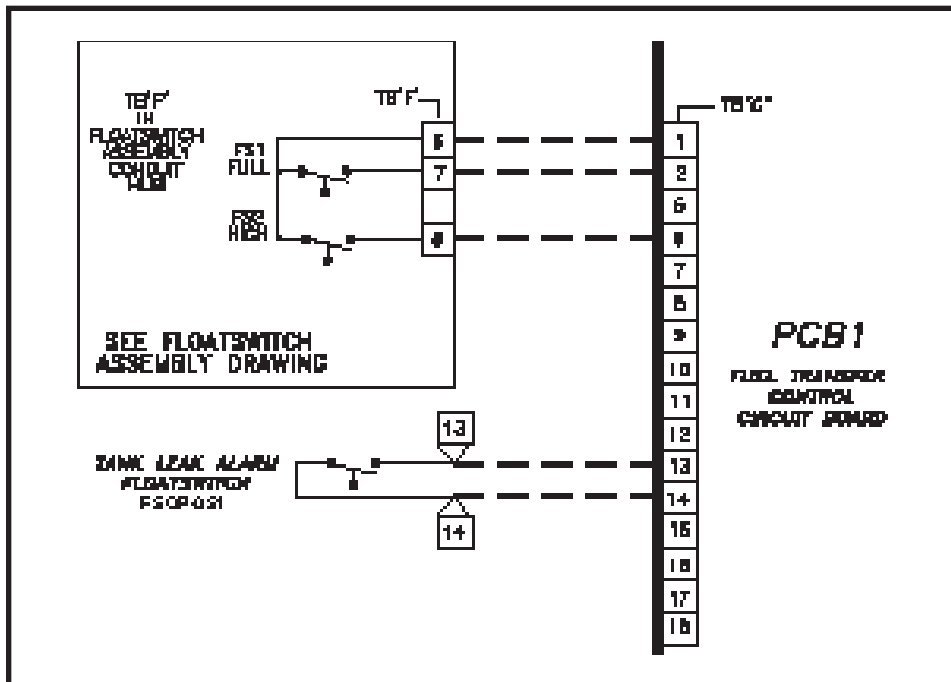

Typical Floatswitch Connections to PCB1

2. See Electrical Drawings:

- a. Using #20 AWG or greater wire, connect the contacts in the Float-switch Assembly Conduit Hub to contacts on Printed Circuit Board 1 (PCB1) as shown.
- b. If needed, using #20 AWG or greater wire, connect optional Tank Leak Alarm Floatswitch to contacts on Printed Circuit Board 1 (PCB1) as shown.

c. If needed, connect customer supplied alarm devices to contacts on PCB1 as shown. Contacts are rated 3A @ 30VDC.

Fill Control Valve Open, Tank Fill Alarm and High Fuel Alarm contacts are standard.

Over Fill Alarm, Tank Leak Alarm and Low Fuel Alarm contacts are optional.

d. Using #20 AWG or greater shielded wire, connect contacts on the back of the Automatic FuelPort to the Level Transducer as shown.

e. Using #14AWG or greater wire, connect control power of 115VAC, 1Ø, 60Hz to contacts at terminal block TB'PS' 1-3 on PCB1 as shown. A 15 amp fuse or circuit breaker is required, maximum, supplied by others.

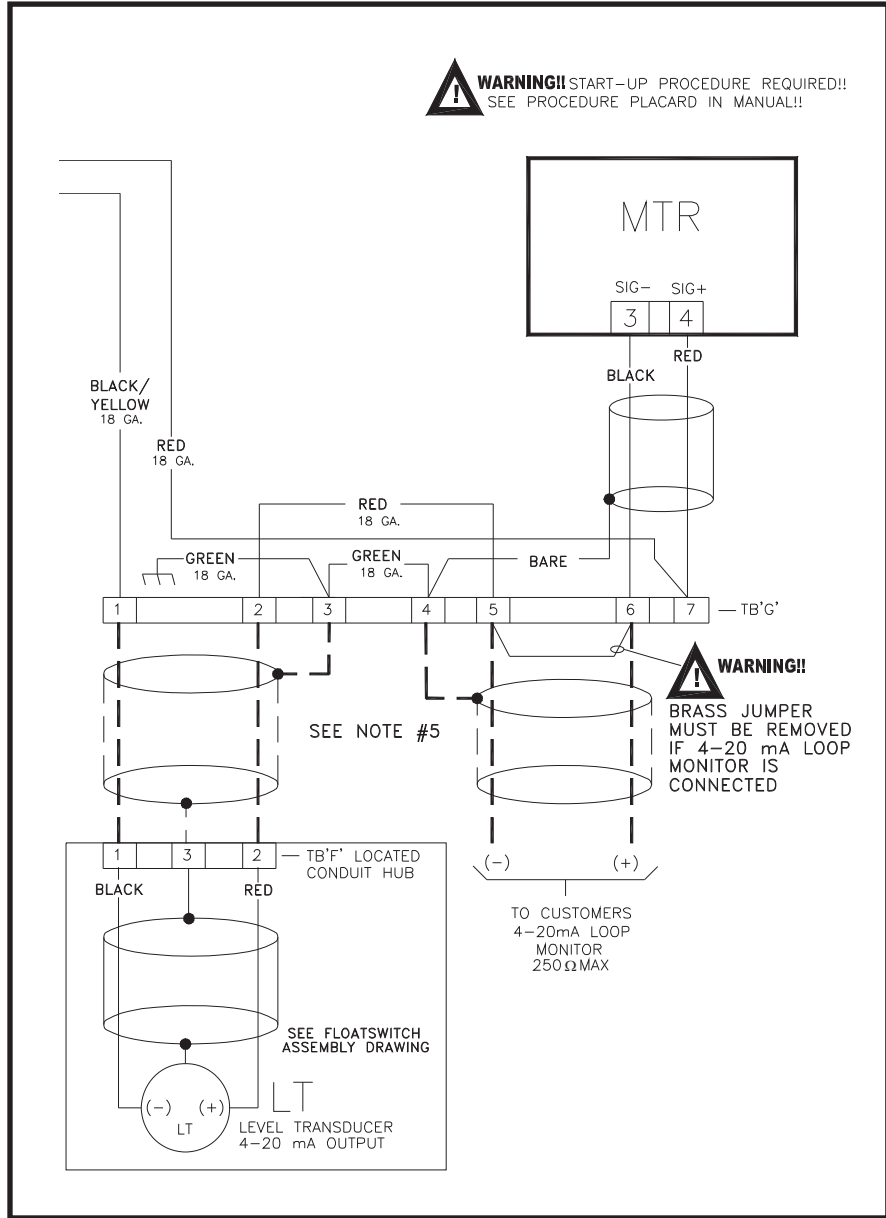

**Typical Transmitter and
TC-25 Receiver / Indicator Electrical Schematic**

AUTOMATIC FUELPORT SEQUENCE OF OPERATION

1. The fuel delivery truck arrives. The driver proceeds to the Automatic FuelPort to make a fuel delivery.
2. Connect a ground cable from the truck to truckers ground stud provided on Automatic FuelPort.
3. Unlock the fill box and connect a delivery hose to the hose coupling in the Automatic FuelPort.
4. Open the valve on truck.
5. Start the delivery pump on the truck.
6. Turn the Control Power switch to the Valve Open position.
7. The Automatic FuelPort valve opens.
8. Fuel is delivered to the tank.
9. Delivery may be stopped at any time by pressing the Close Fill Valve push-button.
10. When the tank is full, audible and visual alarms are activated to alert the driver.
11. The driver may stop delivery by pressing the Close Fill Valve push-button and proceeding to step #14.
12. Stop the delivery pump on the truck.
13. Close the valve on truck.
14. At High Level, audible and visual alarms are activated and the Automatic FuelPort valve closes. The valve cannot be reopened at High Level.
15. Drain the delivery hose.
16. Disconnect the delivery hose from the Automatic FuelPort.

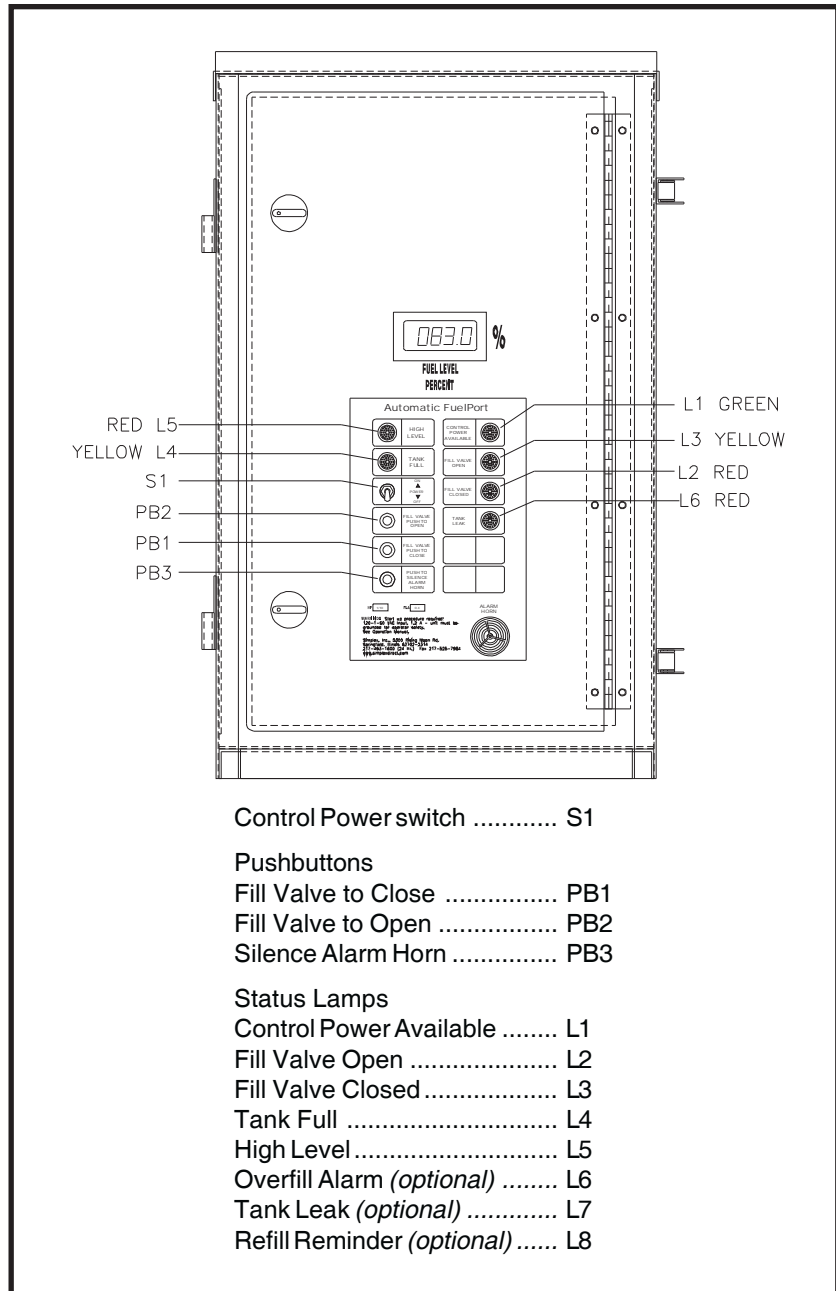

17. Turn the Control Power switch to the Off position.
18. Close and lock the fill box.
19. Fuel delivery is complete.

SPECIFICATIONS**Power**

120VAC or 24VDC (specify),
<100mA

Accuracy

2%

Display

1. 5 Digit LCD
0-9999.9/0-99999

Resolution

Percent display: 1/10 percent

Gallons/liters display:
1/10 unit to 199.9
1 unit to 1999

Temperature range*

Display:
-31 - 167°F
-35 - 75°C

Transmitter:
-50 - 125°F
-46 - 52°C

*Caution: Do not exceed flash
point of tank contents

TC-25 TANK COMMANDER

The TC-25 Tank Commander is an economical instrument for accurate liquid level indication scaled in percent level for cylindrical and square tanks or in gallons/liters for square tanks only. The TC-25 can be in an open construction suitable for flush panel mounting or in a enclosure for wall mounting.

The TC-25 is for use with Class-II liquids (fuel oils, lubricating oils) only. **Do not use with gasoline or other Class I liquids.**

The TC-25 is a fully electronic device using a submersible level transmitter. The Receiver/Indicator displays tank level on a 1-inch LCD display. Level indication can be scaled in percent level for cylindrical tanks and square tanks or in percent level or gallons/liters for square/rectangular tanks.

The Transmitter is installed in a 1½-inch NPT or larger pipe fitting in the tank top. The length of the Transmitter is equal to the inside height of the tank and is available for any tank height. However, transmitters are stocked in 2 standard ranges: 0-68 in. and 0-136 in.

Convenient user adjustment potentiometers allow field calibration for specific tank constructions.

The TC-25 is powered from either 120V AC or 24V DC (voltage must be specified when ordering). Refer to electrical drawing.

The TC-25 has a 4-20 mA output linear with fuel level.

INSTALLATION

TRANSMITTER

The Transmitter is mounted on the tank top and must span entire inside height of tank for an accurate measurement (See *Standard Transmitter Drawing*).

A weatherproof conduit hub with 0.50NPT conduit fittings is provided for electrical connections.

Connection

Using a 3 conductor shielded cable, #20 AWG, connect TC-25 Level Transmitter to terminal block as shown on the electrical drawings.

LEVEL TRANSMITTER OPERATIONAL VERIFICATION

1. Check drawings for changes in specifications (e.g. size of tank, percentage or gallons).
2. If there are no changes in the specifications the unit is ready for a system check.

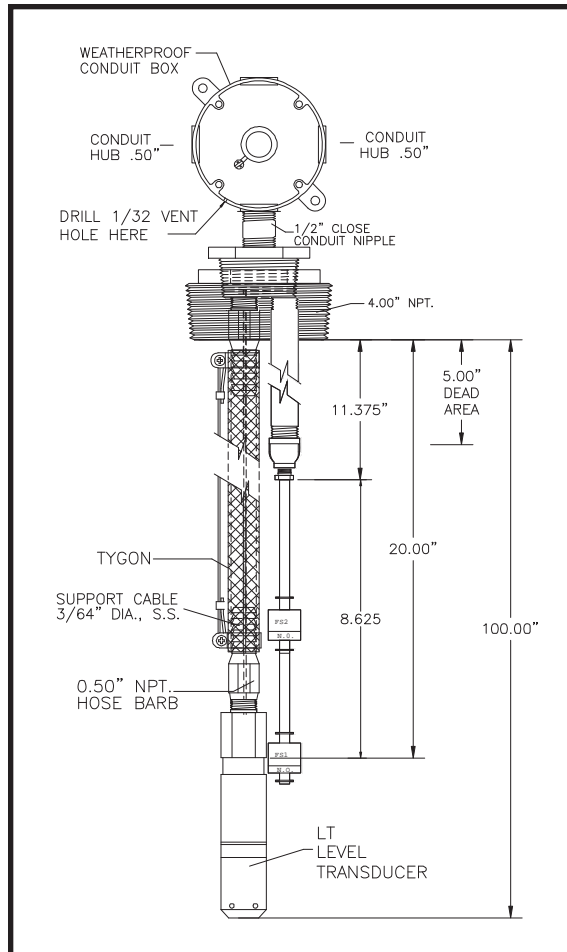

Standard Transmitter

⚠ WARNING ⚠

Care must be taken when installing the system. Incorrect wiring will damage the Receiver/Indicator. Follow drawing provided with system for proper installation.

FIELD CALIBRATION (MAY BE REQUIRED)

1. A final calibration check may be required before the system is fully operational. The “Zero” point is set at the factory and should not need adjustment.

2. Example: Percent level

a. 400 gallon tank is filled with a known 360 gallons of fuel. With the system on, the meter is reading 87% level. Adjust the meter “OFFSET” value within the meter menuing system so the meter reads 90%.

3. The meter can be adjusted to read gallons instead of percent. Use the following adjustment procedures. (RECTANGULAR TANKS ONLY)

4. Example: # of gallons

a. 400 gallon tank is filled with a known 360 gallon volume of fuel. With the system on, the meter reads 87 percent. Adjust the meter “DSP 2” value within the meter menuing system to read 400 gallons . Then adjust the meter “OFFSET” value within the meter menuing system so the meter reads exactly 360 gallons.

5. “OFFSET” value entry:

a. Press and HOLD the “SEL” button to enter the programming mode, you should see PRO on the display.

b. Press the “RST” button once, you should see “1-INP” on the display.

c. Press the “SEL” button three times, you should see “OFSET” on the display.

d. Press the “RST” button once, you should see the right-most digit flashing.

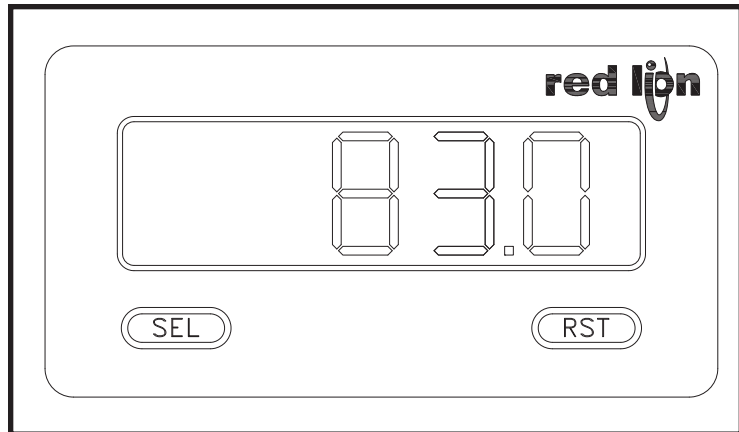

Standard Receiver / Indicator

e. Press the “RST” button multiple times to enter the desired OFFSET value.

f. NOTE: If the desired OFFSET value is to be negative, press the “SEL” button multiple times, you should see the left-most digit flashing. Press the “RST” button multiple times, you should see a “-“ in the left-most digit position.

g. Press and briefly HOLD the “SEL” button once to save the OFFSET entry.

h. Press the “SEL” button multiple times, you should see “PRO NO” on the display.

i. Press the “SEL” button once to exit the programming mode, you should see “END” briefly flash on the display before returning to the numeric displayed value.

6. “DSP 2” value entry:

a. Press and HOLD the “SEL” button to enter the programming mode, you should see PRO on the display.

b. Press the “RST” button once, you should see “1-INP” on the display.

c. Press the “SEL” button ten times, you should see “DSP 2” on the display.

- d. Press the “RST” button once, you should see the right-most digit flashing.
- e. Press the “RST” button multiple times to enter the desired value.
- f. NOTE: The “SEL” button moves from digit to digit, the “RST” button changes the value of each digit.
- g. Enter the total tank volume in gallons, ex. 0400.0.
- h. Press and briefly HOLD the “SEL” button once to save the “DSP 2” entry.
- i. Press the “SEL” button multiple times, you should see “PRO NO” on the display.
- j. Press the “SEL” button once to exit the programming mode, you should see “END” briefly flash on the display before returning to the numeric displayed value.

INCHES OF FUEL TO OUTPUT CURRENT CONVERSION CHART

A = (0-68") Transmitter
PN 25328250

B = (0-136") Transmitter
PN 25328251

mA = TC-25 Current Output

A	B	mA
0	0	4.000
0.5	1	4.118
1.0	2	4.235
1.5	3	4.353
2.0	4	4.471
2.5	5	4.588
3.0	6	4.706
3.5	7	4.824
4.0	8	4.941
4.5	9	5.059
5.0	10	5.176
5.5	11	5.294
6.0	12	5.412
6.5	13	5.529
7.0	14	5.647
7.5	15	5.765
8.0	16	5.882
8.5	17	6.000
9.0	18	6.118
9.5	19	6.235
10.0	20	6.353
10.5	21	6.471
11.0	22	6.588
11.5	23	6.706

A	B	mA
12.0	24	6.824
12.5	25	6.941
13.0	26	7.059
13.5	27	7.176
14.0	28	7.294
14.5	29	7.412
15.0	30	7.529
15.5	31	7.647
16.0	32	7.765
16.5	33	7.882
17.0	34	8.000
17.5	35	8.118
18.0	36	8.235
18.5	37	8.353
19.0	38	8.471
19.5	39	8.588
20.0	40	8.706
20.5	41	8.824
21.0	42	8.941
21.5	43	9.059
22.0	44	9.176
22.5	45	9.294
23.0	46	9.412
23.5	47	9.529
24.0	48	9.647
24.5	49	9.765
25.0	50	9.882
25.5	51	10.000
26.0	52	10.118
26.5	53	10.235

A	B	mA
27.0	54	10.353
27.5	55	10.471
28.0	56	10.588
28.5	57	10.706
29.0	58	10.824
29.5	59	10.941
30.0	60	11.059
30.5	61	11.176
31.0	62	11.294
31.5	63	11.412
32.0	64	11.529
32.5	65	11.647
33.0	66	11.765
33.5	67	11.882
34.0	68	12.000
34.5	69	12.118
35.0	70	12.235
35.5	71	12.353
36.0	72	12.471
36.5	73	12.588
37.0	74	12.706
37.5	75	12.824
38.0	76	12.941
38.5	77	13.059
39.0	78	13.176
39.5	79	13.294
40.0	80	13.412
40.5	81	13.529
41.0	82	13.647
41.5	83	13.765

A = (0-68") Transmitter
PN 25328250

B = (0-136") Transmitter
PN 25328251

mA = TC-25 Current Output

A	B	mA
42.0	84	13.882
42.5	85	14.000
43.0	86	14.118
43.5	87	14.235
44.0	88	14.353
44.5	89	14.471
45.0	90	14.588
45.5	91	14.706
46.0	92	14.824
46.5	93	14.941
47.0	94	15.059
47.5	95	15.176
48.0	96	15.294
48.5	97	15.412
49.0	98	15.529
49.5	99	15.647
50.0	100	15.765
50.5	101	15.882
51.0	102	16.000
51.5	103	16.118
52.0	104	16.235
52.5	105	16.353
53.0	106	16.471
53.5	107	16.588
54.0	108	16.706

A	B	mA
54.5	109	16.824
55.0	110	16.941
55.5	111	17.059
56.0	112	17.176
56.5	113	17.294
57.0	114	17.412
57.5	115	17.529
58.0	116	17.647
58.5	117	17.765
59.0	118	17.882
59.5	119	18.000
60.0	120	18.118
60.5	121	18.235
61.0	122	18.353
61.5	123	18.471
62.0	124	18.588
62.5	125	18.706
63.0	126	18.824
63.5	127	18.941
64.0	128	19.059
64.5	129	19.176
65.0	130	19.294
65.5	131	19.412
66.0	132	19.529
66.5	133	19.647
67.0	134	19.765
67.5	135	19.882
68.0	136	20.000

APPENDIX A - ABBREVIATIONS USED IN THIS MANUAL

Listed below are abbreviations of terms found on Fuel Supply Systems. When following a drawing utilize this guide to define abbreviated system and component names. As this is a master list, drawings and text pertaining to your equipment may not contain all these terms.

AC -Alternating Current	MOT -Motor
AHR -Alarm Horn Relay	N.C. -Normally Closed
AR -Alarm Horn	NEC -National Electric Code
BPRV -Back Pressure Regulating Valve	NEMA -National Electric Manufacturers Association
BRK -Motor/Pump Bracket	NFPA -National Fire Protection Association
BV -Ball Valve	N.O. -Normally Open
C -Contactor	NP -Nameplate
CB -Circuit Breaker	NPT -National Pipe Thread
CSR -Check Strainer Relay	O.D. -Outside Diameter
CV -Check Valve	OLR -Over Load Relay
DC -Direct Current	OPT -Option
DPDT -Double Pole Double Throw	PCB -Printed Circuit Board
F -Fuse	PCRX -Pump Control Relays
FLS -Flowswitch	PG -Pressure Gauge
FS -Floatswitch	PLR -Pipe Leak Relay
FSR -Simplex Fuel Strainer	PRV -Pressure Relief Valve
GA -Gauge	PS -Pressure Switch
GAL -Gallons	PSI -Pounds Per Square Inch
GPM -Gallons Per Minute	PSR -Pressure Switch Relay
HFL -High Fuel Level Relay	PRR -Pump Running Relay
HG -Mercury	SC -Swing Check Valve
HP -Horsepower	SOL -Solenoid
HZ -Hertz	SST -Simplex Super Tank
I.D. -Inside Diameter	TB -Terminal Block
JB -Junction Box	T -Control Transformer
Hz -Hertz	TDR -Time Delay Relay
INHG -Inches of Mercury	TEFC -Totally Enclosed, Fan Cooled
L -Lamp	THR -Tank Heater Control Relay
L.E.D. -Light Emitting Diode	TS -Transducer Pressure Switch
LAFD -Los Angeles Fire Department	V -Voltage
LFF -Loss of Flow Relay	VAC -Voltage, Alternating Current
LFL -Low Fuel Level Relay	VDC -Voltage, Direct Current
LPR -Low Pressure Relay	VG -Vacuum Gauge
MDB -Main Distribution Block	
MDS -Main Disconnect Switch	

APPENDIX B - TECHNICAL DATA

Thermal expansion of oil is approximately 1 cubic inch per 1 gallon per 10°F rise in temperature.

Hydraulic Formulas

$$\text{Horsepower} = \frac{\text{GPM} \times \text{PSI}}{1714}$$

$$\text{Torque (lb. in.)} = \frac{\text{CU IN./REV.} \times \text{PSI}}{2}$$

$$\text{Torque (lb. in.)} = \frac{\text{HP} \times 63025}{\text{RPM}}$$

$$\text{Flow (gpm)} = \frac{\text{CU IN./REV} \times \text{RPM}}{231}$$

Head and Pressure Equivalents

When converting pressure from feet of water to P.S.I., the specific gravity of the liquid must be considered.

Here are some typical conversion figures:

1 P.S.I.=2.30 feet of water
(specific gravity 1.0)

1 P.S.I.=2.88 feet of oil
(specific gravity 0.8)

Conversion Factors

1HP = 33,000 ft. lbs. per minute
1HP = 42.4 btu per minute
1HP = 0.746 kw/hr (kilowatt hours)

1 U.S. gallon= 231 cubic inches

Pipe Volume varies as the square of the diameter; volume in gallons = 0.0034 D² L where:
D=inside diameter of pipe in inches;
L=length in inches

Velocity in feet per sec.= $\frac{0.408 \times \text{flow (gpm)}}{D^2}$

where:

D=inside diameter of pipe in inches

Atmospheric pressure at sea level = 14.7PSI
Atmospheric pressure decreases approximately 0.41PSI for each one thousand feet of elevation up to 23,000 feet.

Pressure (PSI) = feet head x 0.433 x specific gravity

Specific gravity of oil is approximately 0.85.

PRESSURE AND CONVERSION TABLE		
Feet Water	PSI Oil	PSI Water
1	.35	.43
2	.70	.87
3	1.05	1.3
4	1.4	1.73
5	1.75	2.17
10	3.5	4.33
15	5.2	6.5
20	7.0	8.66
25	8.7	10.8
30	10.5	13.0
35	12.2	15.2
40	14.0	17.3
45	15.7	19.5
50	17.5	21.7
55	19.2	23.9
60	21.0	26.0
65	22.7	28.1
70	24.5	30.5
75	26.2	32.5
80	28.0	34.6
85	29.7	36.8
90	31.5	39.0

SUPER X-L PUMP

PUMP MODEL	DISPLACEMENT IN ³ (CC/REV.)	RPM	Flow, GPM (LPM)				
			100 PSI (6.9 Bar)	1000 PSI (69 Bar)	1500 PSI (103 Bar)	2000 PSI (138 Bar)	2500 PSI (172 Bar)
SUPER XL-11	.262 (4.29)	1800	1.99 (7.54)	1.86 (7.05)	1.79 (6.78)	1.73 (6.56)	1.66 (6.29)
SUPER XL-39	.942 (15.44)	1800	7.08 (26.83)	6.87 (26.04)	6.77 (25.66)	6.66 (25.24)	6.56 (24.86)
SUPER XL-62	1.47 (24.14)	1800	11.10 (42.07)	10.81 (40.97)	10.70 (40.55)	10.60 (40.17)	10.40 (39.42)
SUPER XL-90	2.23 (36.5)	1800	16.70 (63.29)	16.50 (62.54)	16.30 (61.78)		
SUPER XL-114	3.35 (54.9)	1800	25.30 (95.89)	24.90 (94.37)	24.60 (93.23)	24.40 (92.48)	

PUMP PERFORMANCE DATA 40 SSU • 200 SSU • 500SSU (SERIES 420)

		40SSU						200SSU											
		0 PSI		50 PSI		100 PSI		0 PSI		50 PSI		100 PSI		200 PSI		300 PSI		500 PSI	
MODEL	RPM	GPM	HP	GPM	HP	GPM	HP	GPM	HP	GPM	HP	GPM	HP	GPM	HP	GPM	HP	GPM	HP
420	1200	1.9	¼	1.7	¼	1.5	⅓	1.9	⅛	1.9	⅛	1.7	¼	1.5	⅓	1.4	½	1.2	¾
	1800	2.9	¼	2.7	½	2.5	½	2.9	⅛	2.8	¼	2.7	⅓	2.5	½	2.3	¾	2.1	1½
422	1200	3.7	⅓	3.4	½	3.1	¾	3.7	⅛	3.4	¼	3.1	¼	2.8	½	3.0	1	2.8	1½
	1800	5.4	½	4.9	¾	4.8	1	5.5	¼	4.9	⅓	4.9	½	4.6	¾	4.3	1½	3.8	2
424	1200	9.0	¼	7.6	¾	6.0	1	9.0	⅓	8.6	½	8.2	1	7.7	2	7.1	3	-	-
	1800	11.5	⅓	11.1	1	10.7	1½	13.7	½	13.3	1	12.9	1½	10.9	3	10.2	5	-	-
426	1200	10.0	¾	8.2	1	6.3	1½	12.0	¾	11.0	1	10.5	1½	-	-	-	-	-	-
	1800	15.0	1	12.2	1½	9.5	3	18.0	1	17.0	1½	16.0	3	-	-	-	-	-	-
428	1200	20.9	¾	17.4	1½	14.0	3	24.5	¾	23.8	1½	23.0	3	-	-	-	-	-	-
	1800	31.2	1½	26.1	3	21.0	5	37.0	1½	36.0	3	35.0	5	-	-	-	-	-	-
429	1200	34.0	1½	29.0	3	22.0	5	41.0	1½	40.0	3	38.5	5	-	-	-	-	-	-
	1800	53.0	3	45.0	5	36.0	7½	61.7	3	61.0	5	60.0	7½	-	-	-	-	-	-

		500SSU											
		0 PSI		50 PSI		100 PSI		200 PSI		300 PSI		500 PSI	
MODEL	RPM	GPM	HP	GPM	HP	GPM	HP	GPM	HP	GPM	HP	GPM	HP
420	1200	1.8	⅛	1.8	⅛	1.7	¼	1.6	⅓	1.4	½	1.1	1
	1800	2.7	¼	2.7	¼	2.6	⅓	2.5	½	2.4	1	2.2	1½
422	1200	3.6	⅛	3.5	¼	3.3	⅓	2.8	½	2.7	¾	2.0	1½
	1800	5.3	¼	5.2	⅓	4.9	½	4.4	1	4.0	1½	3.0	2
424	1200	8.7	½	8.6	¾	8.5	1½	8.2	2	7.8	3	-	-
	1800	2.9	1	12.8	1½	12.7	2	12.5	3	12.0	5	-	-
426	1200	12.0	1	11.5	1½	11.0	2	-	-	-	-	-	-
	1800	18.1	1½	18.0	2	16.3	3	-	-	-	-	-	-
428	1200	24.5	1½	24.0	2	23.7	3	-	-	-	-	-	-
	1800	37.0	3	36.5	5	36.0	5	-	-	-	-	-	-
429	1200	41.0	2	40.0	5	39.5	5	-	-	-	-	-	-
	1800	61.7	5	61.0	5	60.0	7½	-	-	-	-	-	-

PUMP PERFORMANCE DATA 1000 SSU • 5000 SSU • 10000SSU (SERIES 420)

		1000SSU											
		0 PSI		50 PSI		100 PSI		200 PSI		300 PSI		500 PSI	
MODEL	RPM	GPM	HP	GPM	HP	GPM	HP	GPM	HP	GPM	HP	GPM	HP
420	1200	1.9	1/8	1.9	1/8	1.8	1/4	1.7	1/3	1.6	1/2	1.4	3/4
	1800	2.8	1/4	2.7	1/4	2.7	1/4	2.6	1/2	2.5	3/4	2.2	1 1/2
422	1200	3.5	1/4	3.4	1/4	3.3	1/3	3.0	3/4	2.6	3/4	1.8	1 1/2
	1800	5.0	1/3	4.9	1/2	4.9	3/4	4.7	1	4.2	1 1/2	3.4	2
424	1200	8.8	3/4	8.7	1	8.5	1 1/2	8.2	2	7.8	3	-	-
	1800	13.0	1 1/2	12.7	2	12.5	2	10.2	3	9.9	5	-	-
426	1200	12.5	1 1/2	12.0	1 1/2	11.8	2	-	-	-	-	-	-
	1800	18.7	2	18.5	2	17.0	3	-	-	-	-	-	-
428	1200	24.9	2	24.5	3	24.0	5	-	-	-	-	-	-
	1800	37.4	5	37.2	5	36.5	5	-	-	-	-	-	-
429	1200	41.7	3	41.7	5	41.0	5	-	-	-	-	-	-
	1800	61.7	5	61.7	7 1/2	61.0	7 1/2	-	-	-	-	-	-

		5000SSU									10000SSU						
		0 PSI		50 PSI		100 PSI		200 PSI		300 PSI		0 PSI		50 PSI		100 PSI	
MODEL	RPM	PM	HP	GPM	HP	GPM	HP	GPM	HP	GPM	HP	GPM	HP	GPM	HP	GPM	HP
420	1200	-	-	-	-	-	-	-	-	-	-	-	-	-	-	-	-
	1800	-	-	-	-	-	-	-	-	-	-	-	-	-	-	-	-
422	1200	-	-	-	-	-	-	-	-	-	-	-	-	-	-	-	-
	1800	-	-	-	-	-	-	-	-	-	-	-	-	-	-	-	-
424	1200	8.2	1	8.0	1 1/2	7.8	2	7.6	3	7.4	3	-	-	-	-	-	-
	1800	11.2	2	11.0	3	10.7	3	10.2	5	9.9	5	-	-	-	-	-	-
426	1200	12.5	2	12.4	2	11.6	3	-	-	-	-	-	-	-	-	-	-
	1800	18.7	3	18.5	3	17.5	5	-	-	-	-	-	-	-	-	-	-
428	1200	24.9	5	24.9	5	24.5	5	-	-	-	-	23.3	5	23.0	5	22.8	5
	1800	37.4	7 1/2	37.4	7 1/2	37.0	7 1/2	-	-	-	-	-	-	-	-	-	-
429	1200	41.7	5	41.0	5	40.0	7 1/2	-	-	-	-	-	-	-	-	-	-
	1800	61.7	7 1/2	61.7	7 1/2	61.0	10	-	-	-	-	-	-	-	-	-	-

MOTORS FOR PUMP DRIVE *CONTINUOUS DUTY, 40°C, UL RECOGNIZED***Single Phase Motors**

Split Phase Start, Drip Proof, Rigid Base, Class B
Insulation, Moderate Starting Torque, Sleeve Bearing

HP	RPM	Voltage	NEMA Frame	Bearing	Thermal Prot.	Service Factor	Approx. F.L. Amps
1/3	1800	115	48	Sleeve	Auto	1.0	6.6
1/2	1800	115	56	Sleeve	None	1.0	9.2

Capacitor Start, Drip Proof, Rigid Base, Class B Insulation,
High Starting Torque, Ball Bearing

HP	RPM	Voltage	NEMA Frame	Bearing	Thermal Prot.	Service Factor	Approx. F.L. Amps
1/3	1800	115/230	48	Sleeve	Auto	1.0	7.0/3.5
1/2	1800	115/230	56	Sleeve	Auto	1.0	9.2/4.6
3/4	1800	115/230	56	Sleeve	Auto	1.0	10.4/5.2

Capacitor Start, Drip Proof, Rigid Base, Class B Insulation,
Moderate Starting Torque, Sleeve Bearing

HP	RPM	Voltage	NEMA Frame	Thermal Prot.	Service Factor	Approx. F.L. Amps
1	1800	115/208-230	56	Auto	1.15	13.4/6.8-6.7
1 1/2	1800	115/208-230	56H	Auto	1.15	18.0/9.3-9.0
2	1800	115/208-230	145T	None	1.15	21.0/11.3-10.5
3	1800	115/208-230	184T	None	1.15	33.0/16.5
5	1800	208-230	184T	None	1.15	23.0-21.0
7 1/2	1800	208-230	215T	None	1.15	35.2

Capacitor Start, Totally Enclosed, Fan-Cooled, Rigid
Base, Class B Insulation, NEMA-L (>1.0 HP) High Starting
Torque, Ball Bearing

HP	RPM	Voltage	NEMA Frame	Thermal Prot.	Service Factor	Approx. F.L. Amps
1/3	1800	115/208-230	56	Auto	1.15	6.6/3.1-3.3
1/2	1800	115/208-230	56	Auto	1.15	8.8/4.2-4.4
3/4	1800	115/208-230	56	Auto	1.15	11.0/5.4-5.5
1	1800	115/208-230	56	Auto	1.15	13.4/6.8-6.7
1 1/2	1800	115/208-230	56H	Auto	1.15	15.2/8.2-7.6
2	1800	115/208-230	145T	None	1.15	18.8/9.4
3	1800	115/208-230	184T	None	1.0	34.0/17.0
5	1800	208-230	213T	None	1.0	27.5-26.0
7 1/2	1800	208-230	215T	None	1.0	36.5-33.0

MOTORS FOR PUMP DRIVE *CONTINUOUS DUTY, 40°C, UL RECOGNIZED*

Three Phase Motors

Drip Proof, Rigid Base, Class B Insulation, NEMA B, High Starting Torque, Ball Bearing

HP	RPM	Voltage	NEMA Frame	Thermal Prot.	Service Factor	Approx. F.L. Amps
1/3	1800	208-230/460	56	Auto	1.35	1.5-1.6/0.8
1/2	1800	208-230/460	56	Auto	1.35	2.3-2.4/1.2
3/4	1800	208-230/460	56	Auto	1.25	2.9-3.0/1.5
1	1800	208-230/460	56	Auto	1.15	3.5-3.6/1.8
1 1/2	1800	208-230/460	145T	Auto	1.15	4.8-4.8/2.4
2	1800	208-230/460	145T	Auto	1.15	6.2-6.2/3.1
3	1800	208-230/460	145T	Auto	1.15	9.2-8.6/4.3
5	1800	230/460	184T	Auto	1.15	13.2/6.6
7 1/2	1800	230/460	213T	Auto	1.15	20.0/10.0
10	1800	230/460	215T	Auto	1.15	26.6/13.3

Totally Enclosed-Fan-Cooled, Rigid Base, Class B Insulation, Class F (182T -254T), NEMA B, High Starting Torque

HP	RPM	Voltage	NEMA Frame	Approx. F.L. Amps
1/3	1800	208-230/460	56	1.5-1.6/0.8
1/2	1800	208-230/460	56	2.3-2.4/1.2
3/4	1800	208-230/460	56	2.9-3.0/1.5
1	1800	208-230/460	56	3.5-3.6/1.8
1 1/2	1800	208-230/460	145T	4.8-4.8/2.4
2	1800	208-230/460	145T	6.0-5.8/2.9
3	1800	208-230/460	145T	8.6/4.3
5	1800	230/460	184T	14.0-13.2/6.6
7 1/2	1800	230/460	213T	21.0-20.0/10.0
10	1800	230/460	215T	28.0-27.0/13.5

DC Motors - Ampere Ratings and Fuse Sizes

Motors HP	Ratings of DC Motors Full-Load Amperes		Amp. Cap. of Fuses for Recommended Values	
	120 Volts	240 Volts	120 Volts	240 Volts
1/8	1.4	.7	3	3
1/6	1.8	.9	3	3
1/4	2.9	1.5	5	3
1/3	3.6	1.8	5	3
1/2	5.2	2.6	7	3
3/4	7.4	3.7	10	5
1	9.4	4.7	15	7
1 1/2	13.2	6.6	20	10
2	17	8.5	25	12
3	25	12.2	30	15
5	40	20	50	25
7 1/2	58	29	80	40
10	76	38	100	50

Pipe Friction- Fuel Oil 2

Pressure Drop in PSI per 100 feet of Pipe and Tube

NOMINAL SIZES - INSIDE DIAMETERS								
Pipe Size, In.	2.0 GPM	7.0 GPM	10.0 GPM	17.0 GPM	23.0 GPM	30. GPM	40.0 GPM	50.0 GPM
.50	2.337	24.65	56.10	148.75	233.75	408.00		
.75		3.61	7.31	21.25	39.53	64.6	93.5	182.75
1.00	.306	2.00	4.16	11.70	19.55	31.87	54.40	80.75
1.25	.10	.51	1.00	2.55	5.10	8.50	14.88	22.10
1.5		.23	.425	1.10	2.04	3.27	5.70	8.33
2.00			.13	.34	.60	.96	3.10	2.38
2.50			.10	1.62	.30	.51	.94	1.275
3.00					.10	1.74	3.06	4.93

NOTE: Pipe sizes shown apply to standard weight schedule 40 pipe.
Tube is standard copper tubing

FLAMMABLE LIQUIDS FLASH POINTS

Excerpts from NFPA 325, "Fire Hazards properties of Flammable Liquids..."

	Flash Points °F(°C)
Diesel Fuel Oil No. 1-D	100 Min. (38) or Legal
Diesel Fuel Oil No. 2-D	125 Min. (52) or Legal
Diesel Fuel Oil No. 4-D	130 Min. (54) or Legal
Fuel Oil No. 1 (Kerosene) (Range Oil) (Coal Oil)	100-162 (43-72)
Fuel Oil No.2	126-204 (52-96)
Fuel Oil No. 4	142-240 (61-116)
Fuel Oil No. 5 Light Fuel Oil No. 5 Heavy	156-336 (69-169) 160-250 (71-121)
Fuel Oil No. 6	150-270 (66-132)
Jet Fuels Jet A and A-1	110-150 (43-66)
Jet Fuels Jet B	-10 to +30 (-23 to -1)
Jet Fuels JP-4	-10 to +30 (-23 to -1)
Jet Fuels JP-5	95-145 (35-63)

Specific Gravity and Viscosity of Oils

Oils	*Specify Gravity At 60°F	Viscosities In SSU at Various Temperatures							
		30°F	60°F	80°F	100°F	130°F	170°F	210°F	250°F
Auto Lubricating S.A.E.-									
10 Max.	.880 to .935	4,400	1,090	430	240	120	66		
20 Max.	.880 to .935	6,900	1,650	750	400	185	90	57	
30 Max.	.880 to .935	13,000	2,700	1,200	580	255	120	66	49
40	.880 to .935	25,000	4,850	2,000	950	380	150	80	55
50	.880 to .935	58,000	10,000	3,700	1,600	600	220	105	67
60	.880 to .935	100,000	15,000	5,300	2,300	800	285	128	76
70	.880 to .935		22,000	7,500	3,100	1,050	342	150	86
10W	.880 to .935								
20W	.880 to .935								
Fuel Oil-									
Diesel No. 2D	.82 to .95	138	70	53.6	45.5	39			
Diesel No. 3D	.82 to .95	390	145	92	65	48	39		
Diesel No. 4D	.82 to .95	4,400	700	280	140	70	44.2		
Diesel No. 5D	.82 to .95	16,500	3,500	1,500	750	320	136	76.5	54
No. 1	.82 to .95				35				
No. 2	.82 to .95	104	56	45.5	40				
No. 3	.82 to .95	126	68	53	45	39			
No. 5A	.82 to .95	1,480	420	215	125	72	48		
No. 5B	.82 to .95	850	600	490	400	315	235	178	141
No. 6	.82 to .95		72,000	21,500	7,800	2,150	590	225	110
Navy Spec.	.989 Max.	3,300	1,100	600	360	190	100	66	50.2
Navy II	1.0 Max.		24,000	8,600	3,500	1,150	370	160	89
Turbine-									
Heavy	.91 Avg.	4,800	1,280	625	350	170	86	57	
Light	.91 Avg.	770	330	208	138	87	58.8		