

FUEL OIL DAY TANKS

SST Series - Engineering Submittal

SST Series - Advanced Line Day Tanks

Construction:

UL 142 aboveground steel tank all seam welded, square, atmospheric tank of heavy gauge steel with internal reinforcements, tested to 5 PSI test pressure. Welded flange pipe fittings for fuel return, overflow, vent, drain. Submerged fuel oil supply drop tube. Heavy gauge steel channel feet with mounting holes. Separate mechanical and electrical compartments, each with steel housing and removable access covers. Standard equipment:

- 2 GPM SUPER-XL Pump
- SST Controller

Secondary Containment

Option 190: UL142 Secondary Containment Dike

Option 191: Leak Sensor

Super-XL Pump:

The SUPER-XL Pump consists of the following:

- 2 GPM, high vacuum, positive displacement gear pump consisting of two pressure loaded, intermeshing, hardened steel, precision ground gear assemblies within a high strength die cast aluminum housing. Mechanical shaft seal. Pressure loaded to be self-compensating for internal wear.
- 1/3 HP, 120V, single-phase ODP motor. Oversized for high starting torque.
- Motor overload protection
- Optional pumps-motors available.



MODELS

<input type="checkbox"/>	SST 10	10 gal.
<input type="checkbox"/>	SST 25	25 gal.
<input checked="" type="checkbox"/>	SST 50	50 gal.
<input checked="" type="checkbox"/>	SST 75	75 gal.
<input checked="" type="checkbox"/>	SST 100	100 gal.
<input checked="" type="checkbox"/>	SST 150	150 gal.
<input checked="" type="checkbox"/>	SST 200	200 gal.
<input checked="" type="checkbox"/>	SST 275	275 gal.
<input checked="" type="checkbox"/>	SST 325	325 gal.
<input checked="" type="checkbox"/>	SST 400	400 gal.

See SRS Series for 50 gal and above.

SST Level Controller: UL 508 LISTED

Indication Functions

Indicators are long life, extra-bright large display, L.E.D.'s:

- Fuel level
- Power available
- Switch off (flashing)
- Pump running
- Low level alarm
- Overflow alarm/pump control backup activated

Outputs

- Pump start-stop (1HP)
- Low level alarm (60W)
- High level alarm (60W)



Control Functions

120V AC or 24V DC

- "Auto-off-manual" pump control switch
- "Press to test" pump push-button
- Pump start-stop automatic level control
- Automatic disconnect of pump on overflow/high level alarm

SIMPLIX®

Fuel Supply Network



This is an industrial product, not a consumer product. It must be specified, installed, operated and maintained by individuals equipped with the appropriate training and skills. This tank conforms to applicable portions of the following standards: NFPA 30 and NFPA 37, UL 142, UL 508.

All fuel piping should be of black iron or copper pipe. Pipe sizes should follow engine manufacturer's recommendations based on KW of generator set.

WARNING

A Dangerous Installation Will Result If Properly Sized Overflow And Vent Pipes Are Not Connected To This Tank.

Overflow Pipe

Should the tank be overfilled as a result of misadjustment of fuel level controls, fuel spillage or overpressurization of the tank may result. An overflow pipe back to the main storage tank of at least double the size of the fill pipe must be installed with consideration given to length of run and vertical drop. (Use min. 1" I.D.)

Vent Pipe

A properly sized and installed vent pipe is mandatory. The vent provides a means for tank to breathe when fuel is withdrawn or added to tank. Venting also provides pressure relief in case of overfill or rapid expansion or gasification of contents in event of fire. Portions of this tank may become permanently distorted at pressures above 5 PSI, and may rupture at pressures above the designed maximum withstand pressure of 25 PSI. To avoid overpressurization a vent pipe to atmosphere (outside of the building) of the same diameter as the threaded vent fitting installed in the tank must be provided to extend a minimum of 5 ft. above tank top, however, no portion of this vent should extend or terminate more than 12 ft. above this tank. There must be no low portions or sags in the vent pipe which can trap liquid. Protect the open end by suitable means to prevent entry by insects, foreign matter and precipitation.

NOTE:

The emergency vent line capacity specified on the placard at the top of the tank must be considered in order to maintain the fire safety factors established by NFPA 30 and UL 142. If installation is intended to conform and benefit from the inherent safety advantages of the NFPA 30 and UL 142 installation standards, observance of the value is mandatory. It may be necessary to increase the vent pipe diameter if the run is long, or install an emergency vent at the tank.

Maintenance

Every Six Months:

Inspect this tank at least every six months for damage, leakage, or rust on both inside and outside of the tank. Promptly repair or replace any significantly damaged or deteriorated tank.

Annually:

Drain water and sediment from day tank sump at least once each year, or more frequently depending on usage and condition of the fuel.

Recommended Options

Main Storage Tank Is Underground:

When the main fuel storage tank is located underground, one of the following options is recommended to assure maintenance of day tank pump prime. Option 070: Check valve on pump intake, Option 080, 083: Solenoid valve on pump intake, Option 090: Foot valve.

Initial Installation:

Hand pump is recommended for use as a back-up to the motor pump and to prime the motor pump on initial installation. Option 015: 5 GPM (5 strokes/gallon) hand pump.

Special Requirements

Above Ground Storage Tank:

When the main fuel storage tank is located above the level of the day tank, the following options are required; Options 060, 080, 087: Solenoid valve, with fuel strainer, on intake to prevent tank flooding. Consider also: #190/191: Overflow basin and overflow alarm, #383: Overflow-return tank, #390: Overflow return pump and controller.

Piping & Installation

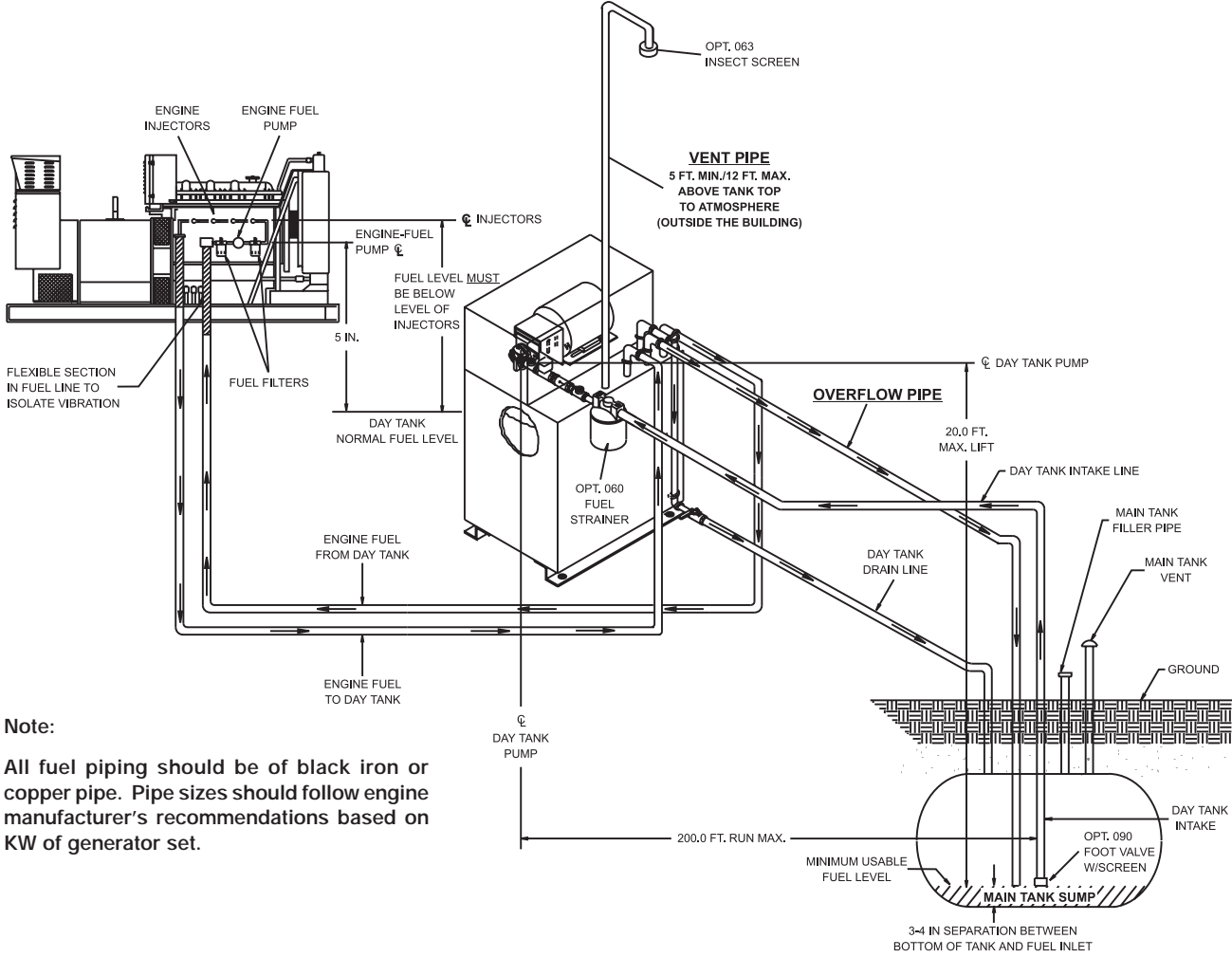

Emergency Vent:

For tanks equipped with emergency tank vent (100-400 gallon), install weighted type emergency vent cap (Option #064) at this fitting. Install vent on 18-inch riser.

Tank Dimensions

10-25 Gallon Tanks

Size	W"	D"	H"	Wgt.
10	24.00	16.00	39.81	126 lbs.
10*	29.25	26.00	41.42	188 lbs.
25	24.00	16.00	52.56	169 lbs.
25*	29.25	26.00	54.17	277 lbs.
50	24.00	22.75	57.06	210 lbs.
50*	31.25	32.50	58.67	398 lbs.
75	24.00	22.75	72.31	212 lbs.
75*	31.25	32.50	73.81	360 lbs.
100	24.00	28.50	72.31	232 lbs.
100*	31.25	38.38	73.81	478 lbs.
150	32.13	28.00	76.56	550 lbs.
150*	42.00	35.00	78.06	826 lbs.
200	32.13	37.50	76.56	610 lbs.
200*	42.00	44.50	78.05	810 lbs.
275	32.13	52.00	76.56	700 lbs.
275*	42.00	59.00	78.05	820 lbs.
325	32.13	60.50	76.56	900 lbs.
325*	42.00	67.75	78.05	1090 lbs.
400	32.13	74.00	76.56	1000 lbs.
400*	42.00	81.25	78.05	1200 lbs.

*with rupture basin

with rupture basin

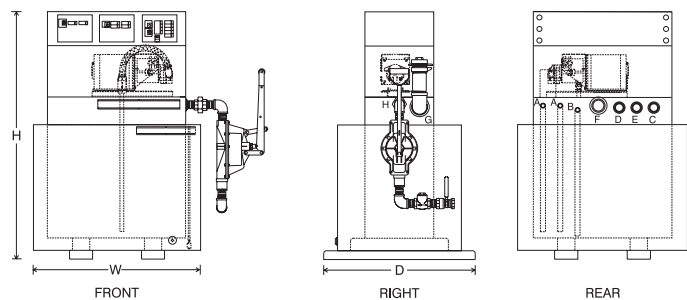
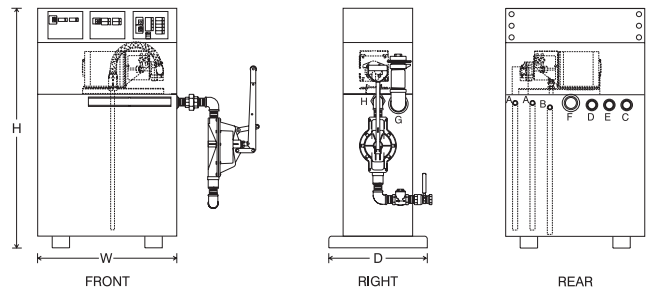

~~50-400 Gallon Tanks~~

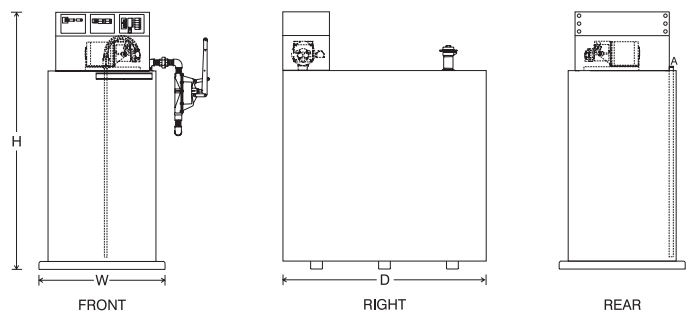

with rupture basin

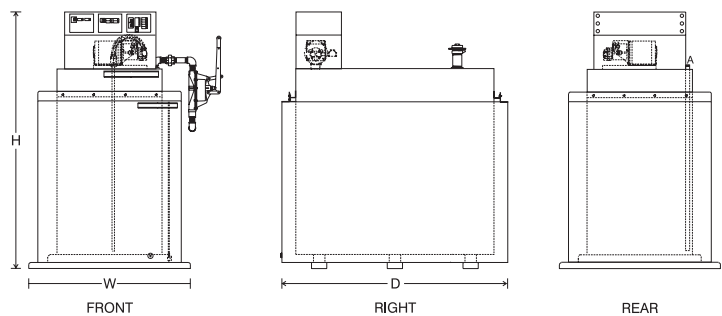

Tank Fittings

Port Description	10-25 Gal. Size "	50-400 Gal. Size "
A Engine Supply Drop Tube	0.50	0.75
B Siphon Drain Drop Tube	0.50	0.75
C Overflow Port	1.00	1.00
D Engine Return Port	1.00	1.00
E Extra Pipe Flange	1.00	1.00
F Tank Vent Port	1.50	2.00
G Manual Fill Port	2.00	2.00
H Hand Pump Mounting Port	0.75	0.75
J Pump Connection To Tank Drop Tube	0.50	0.50
K Floatswitch Mtg./Inspection Port	3.50	3.50
L Pump Motor Mounting Bracket		
M Emergency Tank Vent (100-400 gal.)		4.00

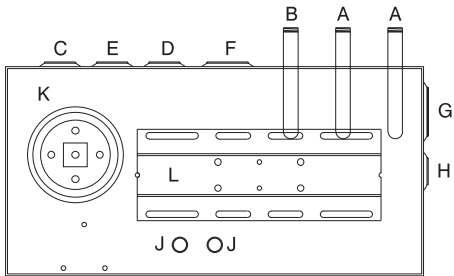
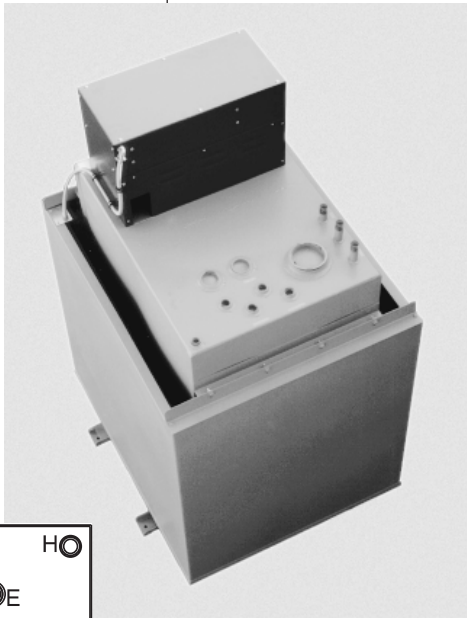

10 - 25 GALLON
TANK FITTINGS - TOP VIEW

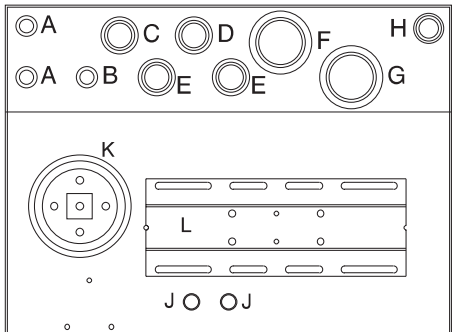

~~50 - 75 GALLON~~
TANK FITTINGS - TOP VIEW

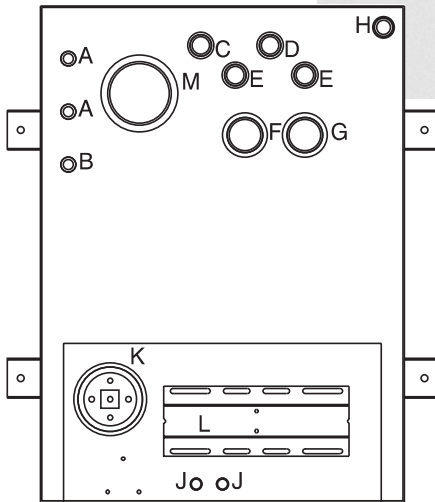

~~100 - 400 GALLON~~
TANK FITTINGS - TOP VIEW

Finish

Rust-inhibitor coated interior. Exterior of tank chemically treated to resist corrosion, primed and finish painted light gray. Top cover painted blue.

Control Panel Wiring

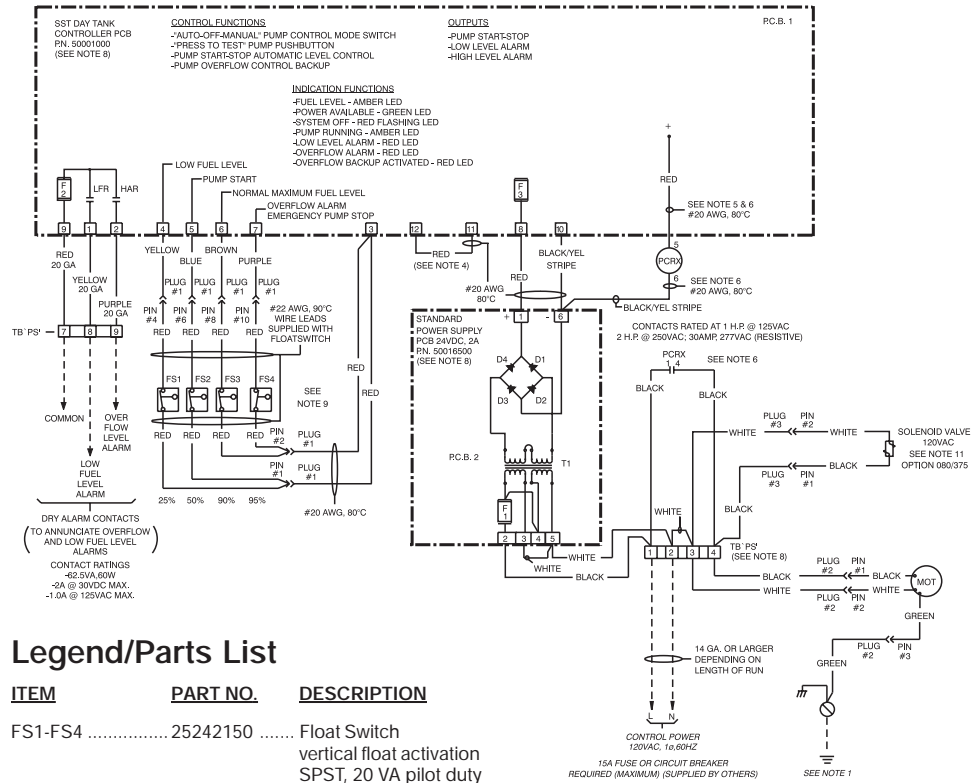

Legend/Parts List

ITEM	PART NO.	DESCRIPTION
FS1-FS4	25242150	Float Switch vertical float activation SPST, 20 VA pilot duty switch logic by reversing float
MOT	24626100	Motor Standard 1/3 Hp, 115V, 1ø, 60 Hz, 6.6 Fla, thermally protected, auto reset
MOT	24630000	Optional Motor Option 700 1/2 Hp, 115V, 1ø, 60 Hz, 9.2 Fla, thermally protected, auto reset
TB'PS'	25663400	Terminal Block 20A, 30V, 12 line
SST Day Tank	50001000	Liquid Level Controller P.C.B.1 printed circuit board, 24VDC input supply voltage, 4 liquid level inputs
Standard	50016500	Power Supply P.C.B.2 printed circuit board 120 VAC input, 2 A fused, 24 DC output (full wave rectified), 56 VA

Serviceable SST PCB Component Parts

ITEM	SIMPLEX PART NO.	DESCRIPTION
Indicators	24249650	Green LED, Socket Mount
	24249700	Amber LED, Socket Mount
	24249600	Red LED, Socket Mount
PCRX	24832000	Motor Starting Contactor 24 VDC Coil, 1 pole, normally open Contacts rated at 1 Hp @ 125 VAC 2 Hp @ 250 VAC 30 Amp, 277 VAC (resistive)
F1-F3	14010000	Fuse 2A, 250 VAC, AGC-2

Mechanical

- 010 Auxiliary hand pump
- 015 Auxiliary hand pump
- 025 Locking manual fuel fill cap
- 040 Wall-mounting brackets
- 050 Pipe stand adapter
- 060 Fuel strainer
- 062 Duplex strainer
- 063 Vent cap
- 064 Emergency vent
- 065 Drain hand valve
- 068 Emergency quick-drain
- 070 Priming tee & check valve assembly
- 080 AC Solenoid valve
- 083 DC Solenoid valve
- 087 Manual shut-off valve, bronze
- 088 Manual shut-off valve, fire rated
- 090 Foot valve
- 093 Fusible link valve
- 095 Pressure relief valve
- 100 Pressure gauge
- 101 Vacuum gauge
- 103 Flow gauge
- 104 Ball motion flow indicator
- 120 Extra 1" NPT pipe connection
- 125 Extra supply suction tube
- 130 Oversize pipe connection, 1 ¼" to 2 ½" NPT
- 131 Oversize pipe connection, 3" to 6" NPT
- 140 Special paint color
- 141 Epoxy primer
- 150 Extra-heavy tank construction
- 180 Weatherproof Modification
- 185 2 or 3 complete day tanks mounted on common base
- 190 Overflow basin
- 191 Rupture float switch
- 192 Basin drain hand valve
- 194 Gravity drain for overflow basin, use with option 190
- 195 Screen top for overflow basin
- 196 Weatherproof cover for overflow basin

Control Devices and Alarms

- 260 Disconnect switch
- 261 System circuit breaker
- 262 Control power transformer
- 265 Day tank heater
- 270 Power available green pilot light
- 280 Operation mode selector switch
- 285 Loss of flow alarm
- 295 Remote low fuel level alarm dry signal contacts

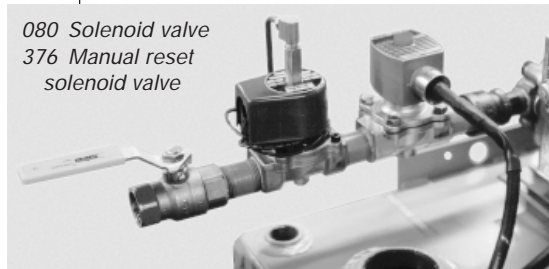

080 Solenoid valve
376 Manual reset solenoid valve



180 Weatherproof Modification
190 Overflow basin
196 Weatherproof cover

- 297 Remote high fuel level alarm dry signal contacts
- 299 Auxiliary relay, use w/options 295 & 297 above
- 311 Local/remote low fuel level alarm, sensing 30% of capacity
- 312 Local/remote high fuel level alarm, sensing 103% of capacity
- 325 High fuel level emergency pump-stop switch
- 326 High level cutout for SDE Series only
- 329 Low fuel level red light
- 333 Critical low fuel level alarm-engine shut down
- 334 Alarm horn
- 340 "Pump Running" amber light

Options Checklist

Options Checklist cont'd

Duplex Pump Systems

- 345 Multifunction duplex pump controller
- 346 Two running time meters
- 347 Manual duplex pump selector switch

Gravity Fed Day Tanks

- 060, Solenoid valve,
- 080, with fuel strainer, on
- 087 intake to prevent tank flooding
- 376 Manual reset, normally open, electrically operated valve
- 377 Siphon-break solenoid valve for remote installation
- 378 Anti-siphon valve
- 383 Overflow-return tank
- 390 Overflow return pump & controller
- 150 Extra-heavy tank construction
- 190, Overflow basin and
- 191 Overflow alarm

Sight Glasses

- 211 Safety sight glass without rupture basins
- 212 Electric level gauge on tanks, 12" min. tank depth
- 214 Digital fuel flow indicator

Fuel Oil Coolers

- 396 Radiator with electric fan, flow switch

Pumps and Motors

- 002 Deletion of Standard Pump & Motor. 10A @ 125/250V AC, 10A @ 30V DC, Form C contacts provided
- 400 7 GPM pump
- 410 10 GPM pump
- 415 17 GPM pump
- 417 25 GPM pump
- 420 3 GPM pump
- 422 5 GPM pump
- 424 11 GPM pump
- 426 13 GPM pump
- 428 36 GPM pump
- 430 45 GPM pump
- 432 61 GPM pump
- 510 Transformer, 480/120V AC, 1ø, 50-60 Hz
- 511 Transformer, 480/120V AC, 1ø, 50-60 Hz
- 605 1/3 HP, 230V AC, 1ø, 60 Hz motor, ODP

- 615 1/3 HP, 110V AC, 1ø, 50 Hz motor, ODP
- 616 1/3 HP, 220V AC, 1ø, 50 Hz motor, ODP
- 621 1/3 HP, 230/460V AC, 3ø motor, ODP, w/starter
- 622 1/3 HP, 230/460V AC, 3ø motor, TEFC, w/starter
- 630 1/3 HP, 12V DC motor
- 635 1/3 HP, 24V DC motor
- 645 1/3 HP, 115V AC, 1ø, 60 Hz, motor, TEFC
- 700 1/2 HP, 115V AC, 1ø, 60 Hz motor, ODP
- 705 1/2 HP, 230V AC, 1ø, 60 Hz motor, ODP
- 715 1/2 HP, 110V AC, 1ø, 50 Hz motor, ODP
- 716 1/2 HP, 220V AC, 1ø, 50 Hz motor, ODP
- 721 1/2 HP, 230/460V AC, 3ø motor, ODP
- 722 1/2 HP, 230/460V AC, 3ø motor, TEFC, w/starter
- 730 1/2 HP, 12V DC motor
- 735 1/2 HP, 24V DC motor
- 745 1/2 HP, 230/115V AC, 1ø, 60 Hz motor, TEFC
- 768 Single phase magnetic motor starter
- 770 3-phase magnetic motor starter
- 800 3/4 HP, 115V AC, 1ø, 60 Hz motor, ODP
- 805 3/4 HP, 230V AC, 1ø, 60 Hz motor, ODP
- 825 3/4 HP, 230/460V AC, 3ø, 60 Hz motor, ODP, w/starter
- 900 1 HP, 115V AC, 1ø, 60 Hz motor, ODP
- 905 1 HP, 230V AC, 1ø, 60 Hz motor, ODP
- 925 1 HP, 230/460V AC, 3ø, 60 Hz motor, ODP, w/starter

Optional motors requiring SPS/SKS Pump Set when used with 10 through 400 gallon models

- 1000 1 1/2 HP, 115V AC, 1ø, 60 Hz motor, ODP
- 1005 1 1/2 HP, 230V AC, 1ø, 60 Hz motor, ODP
- 1025 1 1/2 HP, 230/460V AC, 3ø, 60 Hz motor, ODP, w/starter
- 1100 2 HP, 115V AC, 1ø, 60 Hz motor, ODP
- 1105 2 HP, 230V AC, 1ø, 60 Hz motor, ODP
- 1125 2 HP, 230/460V AC, 3ø, 60 Hz motor, ODP, w/starter
- 1200 3 HP, 115V AC, 1ø, 60 Hz motor, ODP
- 1205 3 HP, 230V AC, 1ø, 60 Hz motor, ODP
- 1225 3 HP, 230/460V AC, 3ø, 60 Hz motor, ODP, w/starter
- 1305 5 HP, 230V AC, 1ø, 60 Hz motor, ODP
- 1322 5 HP, 230V AC, 3ø, 60 Hz motor, TEFC
- 1325 5 HP, 230/460V AC, 3ø, 60 Hz motor, ODP, w/starter
- 1405 7 1/2 HP, 230V AC, 1ø, 60 Hz motor, ODP
- 1422 7 1/2 HP, 208V AC, 3ø, 60 Hz motor, ODP
- 1425 7 1/2 HP, 230/460V AC, 3ø, 60 Hz motor, ODP, w/starter